

All-optical switching in metamaterial with high structural symmetry

Bistable response of nonlinear double-ring planar metamaterial

Vladimir R. Tuz^{1,2} and Sergey L. Prosvirnin^{1,2}

¹ Institute of Radioastronomy, National Academy of Sciences of Ukraine, 4, Krasnoznamennaya st., Kharkiv 61002, Ukraine

² School of Radio Physics, Karazin Kharkiv National University, 4, Svobody Square, Kharkiv 61077, Ukraine

Received: date / Revised version: date

Abstract. We argue the possibility of realization of a polarization-insensitive all-optical switching in a planar metamaterial composed of a 4-fold periodic array of two concentric metal rings placed on a substrate of nonlinear material. It is demonstrated that a switching may be achieved between essentially different values of transmission near the resonant frequency of the high-quality-factor Fano-shape trapped-mode excitation.

1 Introduction

Optical bistability is an area of modern optics which is evolving rapidly. The great attention to this phenomenon is due to the possibility of its practical application to design optical switches, limiters, transistors and diodes. Typically, in bistable devices, the nonlinear medium is placed inside an optical cavity, just as is done in lasers, but unlike the latter they are passive bistable devices whose operating conditions are easy to control because the light propagation is controlled with light [1]. A classical example of

the bistable device is a Fabry-Perot interferometer, filled with a Kerr nonlinear material. In this case, the resonator provides feedback, which is essential to obtain a multivalued intensity at the structure's output. However, in such a system, both relatively strong light power and/or large enough volume of nonlinear optical material are generally needed to achieve a sizeable nonlinear response.

To overcome these drawbacks, photonic crystal microcavities [2] and quantum well structures [3] were proposed to enhance the nonlinear effects as well as to reduce the material volume. With the assistance of surface plasmon polaritons to the effects of confining and enhancing the lo-

cal optical field intensity, optical bistability has also been shown numerically in different metal nanostructures such as surface plasmon polaritonic crystals [4], subwavelength gratings that consisted of infinitely long slits in metal slab [5], [6], etc. In all these cases, the excitation of high-quality-factor resonances in the systems is provided to obtain efficient switching.

A promising way to produce optical switching in compact devices can be found also in using planar metamaterials. It is known that the planar metamaterials can create an environment equivalent to a resonant cavity. As usual such structures are composed of metallic elements in the form of symmetrical split-ring resonators [7], [8]. They are resonant because of an internal capacitance and inductance within each element. Most often such structures are investigated in order to obtain a negative refraction index over a finite frequency range, although their nonlinear optical response was also studied [9]-[11]. Unfortunately a considerable disadvantage of such structures in the context of obtaining optical switching consists in their low quality factor.

Nevertheless, exceptionally strong and narrow resonances are possible in planar metamaterials via engaging trapped modes [12]. The quality factor of the system depends on ratio of power of stored energy to power of radiation and dissipation losses. If we suppose infinitesimal dissipation losses in the structure, the trapped modes correspond to real eigenvalues (i.e., real resonant frequencies) of the relevant boundary value problem due to a special geometry of metal elements. In the regime of quasi-trapped

mode excitation of an actual structure, the field is strongly localized to the structure plane and resonant transmission and reflection have a large quality factor due to very small radiation of electromagnetic energy in a comparison with stored one.

Typically, metamaterials which can bear trapped modes consist of identical subwavelength metallic inclusions structured in the form of asymmetrically split rings [12], [13], split squares [14], [15] or their complementary pattern [16], [15]. These elements are arranged periodically and placed on a thin dielectric substrate. In the structure of such kind, the high-quality-factor current oscillations with the lowest total emission losses appear when all currents in the metallic elements of a periodic cell oscillate in antiphase. The characteristic feature of such metamaterials is the dependence of their spectra on the polarization and the angle of incidence of input waves. In [17], [18], the polarization insensitive structure configurations also were proposed. One such structure consists of a planar array with a periodic cell element that consists of two concentric rings (double-ring (DR) structure).

In the DR-structure, the trapped-modes excitation is exclusively controlled by the difference in circumferences of the inner and outer rings and does not depend on the polarization state of the normally incident electromagnetic radiation. In contrast to the asymmetrically split rings metamaterials, DR-structure is a system, where mutual coupling between elements of neighboring cells is weak and the response of the entire array is practically a direct sum of the DR individual contributions. As a consequence,

the electromagnetic response of the DR-metamaterial is weakly dependent on the angle of incidence [19]. Remarkably, at the trapped-mode resonance the electromagnetic energy is confined to a very small region between the rings, where the energy density reaches substantially high values. This makes the response of the metamaterial operating in the trapped-mode regime extremely sensitive to the dielectric properties of the substrate. This feature can be used for enhancing optical nonlinear response in the nanoscaled version of the metamaterial [20].

The goal of this paper is to show promising use of planar metamaterials that bear the trapped-mode resonances to obtain all-optical switching. Especially, we argue the possibility of realization of a polarization-insensitive all-optical switching in planar metamaterial designed on the basis of double-ring array placed on a substrate of nonlinear dielectric in the regime of trapped-mode excitation.

2 Problem statement and solution

The square unit cell ($d = d_x = d_y$) of the structure under study consists of one DR (Fig. 1). The radii of the outer and inner rings are fixed at $a_1/d = 0.36$ and $a_2/d = 0.29$, respectively. The width of both the metal rings is $2w/d = 0.05$. The array is placed on a nonlinear dielectric substrate with thickness $h/d = 0.2$. As a suitable variant of substrate material we propose semiconductors appropriate in the mid-IR region of wavelength, for example, InSb or InSb with some impurities such as As, Tl, Bi, P [21]. From the experimental results [22]-[24], we expect that the Kerr-nonlinear part of the refractive

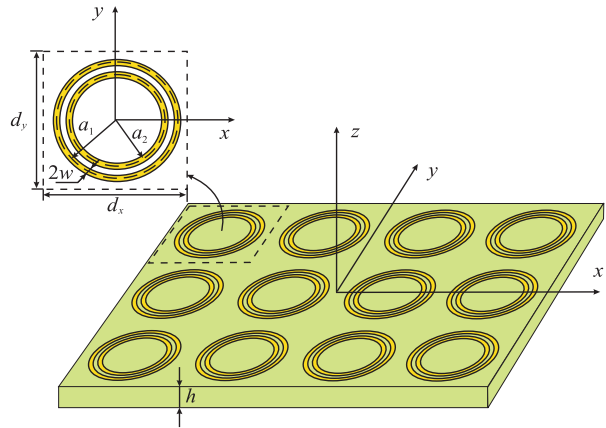

Fig. 1. (Color online) Fragment of the planar metamaterial and its elementary unit cell.

index of these materials in the mid-IR range is between 10^{-4} cm²/kW and 10^{-2} cm²/kW.

As the excitation field a normally incident plane monochromatic wave of a frequency ω and an amplitude A is selected. We suppose that the intensity of the incident field is enough for the nonlinearity to become apparent, i.e., it is about 1 kW/cm².

In the set of our previous works [12], [13], [17]-[20] the method of moments [25] was used to calculate the response of different planar metamaterials in the microwave range when the amplitude of the incident wave is small (linear case). This numerical method involves solving an integral equation for the surface currents induced in the metallic pattern by the incident electromagnetic wave, then calculating the scattered fields produced by the currents as a superposition of partial spatial waves. In the framework of this method it is implied that the metallic pattern is a thin perfect conductor.

On the other hand in [15], on the basis of the pseudo-spectral time-domain algorithm, the optical response of

the metamaterial in the IR range was calculated taking into account the strong dissipation and dispersion of the metal permittivity of the elements. It was revealed that the trapped-mode resonances are well observed and have high Q-factor in this range, and the obtained results are in good agreements with the ones evaluated with the method of moments down to the mid-IR region.

Thus in the present paper we will use the method of moments to calculate the magnitude of the current J along the single ring of the DR element, the reflection r and transmission t coefficients. They can be determined in the form:

$$J = J(\omega, \varepsilon), \quad t = t(\omega, \varepsilon), \quad r = r(\omega, \varepsilon). \quad (1)$$

Next we suppose that the structure substrate is a Kerr nonlinear dielectric whose permittivity ε depends on the intensity of electric field I_{in} inside it. Under rigorous consideration, the nonlinear permittivity ε of the substrate is inhomogeneous. The permittivity reaches its maximum value directly under the metallic pattern and along the rings this permittivity is also different. Nevertheless, as mentioned above, at the trapped-mode resonance, the electromagnetic energy is confined to a very small region between the rings and the crucial influence of the permittivity on the system properties occurs in this place. Therefore, the approximation based on the transmission line theory can be used here to estimate the field intensity between the rings. According to this theory, conductive rings are considered as two wires with a distance b between them. Along these wires the currents flow in opposite directions. Thus the electric field strength is defined

as

$$E_{in} = V/b,$$

where $V = ZJ$ is the line voltage, $b = a_1 - a_2 - 2w$, J is the magnitude of current which flows along the DR-element, and Z is the impedance of line. The impedance is determined at the resonant dimensionless frequency $\varepsilon_0 = d/\lambda_0$,

$$Z = 60 \frac{l\varepsilon_0}{dC_0},$$

where $l = \pi(a_1 + a_2)/2$, and

$$C_0 = \frac{1}{4} \ln \left[\frac{p}{2w} + \sqrt{\left(\frac{p}{2w}\right)^2 - 1} \right]$$

is the capacity in free space per unit length of line, $p = a_1 - a_2$. From this model it follows that the electric field strength between the rings is directly proportional to the current magnitude J . Since the unit cell is small in comparison with the wavelength, the current magnitude J can be substituted with its value averaged along the metallic ring, \bar{J} .

Thus, from this model it follows that the electric field strength between the rings is directly proportional to the average current magnitude \bar{J} , and the nonlinear equation on the average current magnitude in the metallic pattern is obtained in the form

$$\bar{J} = A \cdot \bar{J}(\omega, \varepsilon_1 + \varepsilon_2 I_{in}(\bar{J})). \quad (2)$$

The incident field magnitude A is a parameter of equation (2). At a fixed frequency ω , the solution of this equation is the average current value which is dependent on the magnitude of the incident field, $\bar{J} = \bar{J}(A)$.

On the basis of the current $\bar{J}(A)$ found by a numerical solution of equation (2), the value of the permittivity of

the nonlinear substrate $\varepsilon = \varepsilon_1 + \varepsilon_2 I_{in}(A)$ is determined and the reflection and transmission coefficients (1) are calculated

$$t = t(\omega, \varepsilon_1 + \varepsilon_2 I_{in}(A)), \quad r = r(\omega, \varepsilon_1 + \varepsilon_2 I_{in}(A)), \quad (3)$$

as the functions of the frequency and magnitude of the incident field.

It should be noted here that our treatment of nonlinearity in the planar metamaterial differs from the ones considered earlier in [9]-[11] where some effective medium parameters were introduced to obtain the nonlinear double negative materials.

3 Numerical results

In the case of the nonlinear permittivity of substrate, dependences of the inner intensity and the transmission coefficient magnitude versus the incident field magnitude $I_{in} = I_{in}(A)$ are typical and have the form of hysteresis (Fig. 2). Such form of curves of the transmission coefficient magnitude is studied quite well [1] and can be understood from the following considerations. Suppose that the trapped mode resonant frequency is slightly higher than the incident field frequency. As the intensity of the incident field rises, the magnitude of currents on the metal elements increases. This leads to increasing the field strength inside the substrate and its permittivity as well. As a result, the frequency of the resonant mode decreases and shifts toward the frequency of incident wave, which, in turn, enhances further the coupling between the current modes and the inner field intensity in the nonlinear sub-

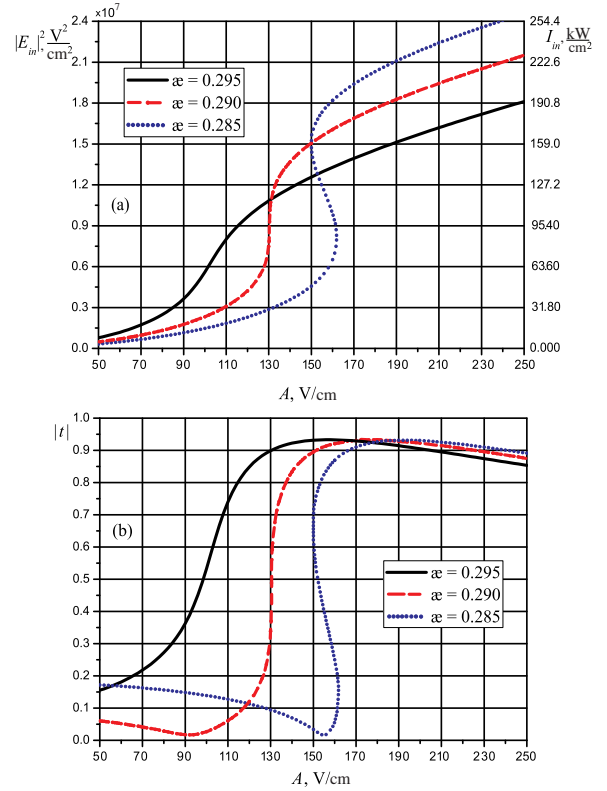

Fig. 2. (Color online) (a) The inner intensity and (b) the magnitude of the transmission coefficient versus the incident field magnitude in the case of the nonlinear permittivity of the substrate. For this and further calculations we use the substrate parameters $\varepsilon_1 = 4.1 + 0.02i$ and $\varepsilon_2 = 5 \times 10^{-3} \text{ cm}^2/\text{kW}$. The value of dimensionless frequency $\varepsilon = d/\lambda$ is chosen a bit lower to the frequency of the trapped-mode resonance ($\varepsilon_0 = 0.3$).

strate. This positive feedback increases the slope of the rising edge of the transmission spectrum, as compared to the linear case. As the frequency extends beyond the resonant mode frequency, the inner field magnitude in the substrate decreases and the permittivity goes back toward its linear level, and this negative feedback keeps the resonant frequency close to the incident field frequency. As a result,

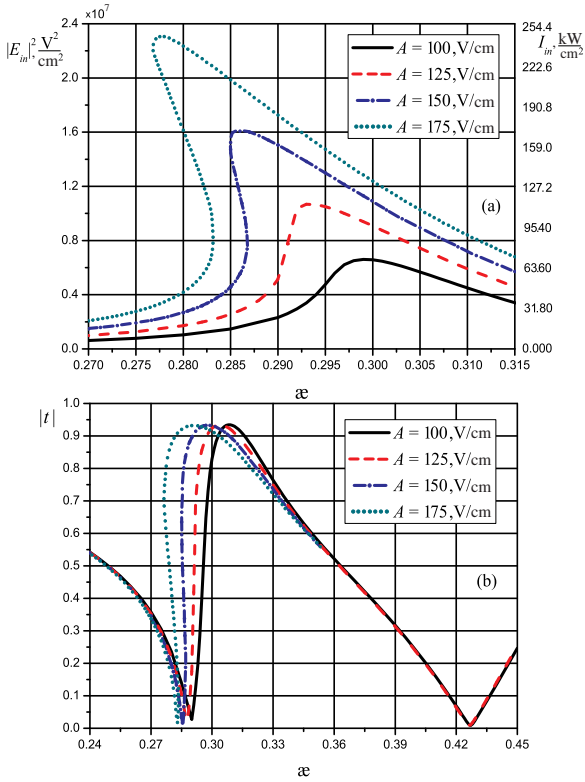

Fig. 3. (Color online) Frequency dependences of (a) the inner intensity and (b) the magnitude of the transmission coefficient in the case of the nonlinear permittivity ($\varepsilon_1 = 4.1 + 0.02i$ and $\varepsilon_2 = 5 \times 10^{-3} \text{ cm}^2/\text{kW}$) of the substrate.

at a certain intensity of the incident field, the transmission coefficient stepwise changes its value from small to large level.

The frequency dependences of the transmission coefficient magnitude also manifests discontinuous switching from small to large level with frequency increasing (Fig. 3). This switching appears closely to the resonant frequency of the trapped-mode excitation. The main peculiarity of the observed resonance is that this trapped-mode resonance in DR-structure has the Fano-shape rather than the Lorentzian one, as is the characteristic of Fabry-Perot cav-

ities. The Fano-type resonance appears as a result of the interference between a high-quality resonance and a much smoother, continuum-like spectrum and typically exhibits a sharp asymmetric line shape with the transmission coefficients varying from 0 to 1 over a very narrow frequency range [26]. Such form of resonance is very suitable to obtain great amplitude of switching since there are gently sloping bands of the high reflection and transmission before and after the resonant frequency.

4 Conclusion

In conclusion, a planar DR nonlinear metamaterial, which bears a high-quality-factor Fano-shape trapped-mode resonance, is promising object for a realization of a polarization-insensitive all-optical switching.

This work was supported by the National Academy of Sciences of Ukraine under the Program "Nanotechnologies and Nanomaterials", Project No. 1.1.3.17.

References

1. H. M. Gibbs, *Optical Bistability: Controlling Light with Light*, (Academic Press, Orlando, 1985).
2. M. Soljačić, C. Luo, J. D. Joannopoulos, and S. Fan, *Opt. Lett.* **28**, 637 (2003).
3. X. Chen, *J. Opt. B: Quantum Semiclass. Opt.* **1**, 524–528 (1999).
4. G. A. Wurtz, R. Pollard, and A. V. Zayats, *Phys. Rev. Lett.* **97**, 057402 (2006).
5. C. Min, P. Wang, C. Chen, Y. Deng, Y. Lu, H. Ming, T. Ning, Y. Zhou, and G. Yang, *Opt. Lett.* **33**, 869, 2008.

6. L. Kochetova, S. Prosvirnin, and V. Tuz, *J. Electromagn. Waves Appl.* **24**, 2249–2257 (2010).
7. S. O’Brien and J. B. Pendry, *J. Phys.: Condens. Matter* **14**, 4035–4044 (2002).
8. S. O’Brien and J. B. Pendry, *J. Phys.: Condens. Matter* **14**, 6383–6394 (2002).
9. J. B. Pendry, A. J. Holden, D. J. Robbins, and W. J. Stewart, *IEEE Trans. Microwave Theory Tech.* **47**, 2075–2084 (1999).
10. A. A. Zharov, I. V. Shadrivov, and Yu. S. Kivshar, *Phys. Rev. Lett.* **91**, 037401 (2003).
11. S. O’Brien, D. McPeake, S. A. Ramakrishna, and J. B. Pendry, *Phys. Rev. B* **69**, 241101(R) (2004).
12. S. Prosvirnin and S. Zouhdi, *Resonances of closed modes in thin arrays of complex particles*, in *Advances in Electromagnetics of Complex Media and Metamaterials*, edited by S. Zouhdi and M. Arsalane. (Kluwer, The Netherlands, 2003) pp. 281–290.
13. V. A. Fedotov, M. Rose, S. L. Prosvirnin, N. Papasimakis, and N. I. Zheludev, *Phys. Rev. Lett.* **99**, 147401 (2007).
14. I. A. I. Al-Naib, C. Jansen, and M. Koch, *Proc. 3rd European Conf. Antennas Propag. (EuCAP, Berlin)* 355–357 (2009).
15. V. V. Khardikov, E. O. Iarko, and S. L. Prosvirnin, *J. Opt.* **12**, 045102 (2010).
16. Z. L. Sámson, K. F. MacDonald, F. De Angelis, B. Gholipour, K. Knight, C. C. Huang, E. Di Fabrizio, D. W. Hewak, and N. I. Zheludev, *Appl. Phys. Lett.* **96**, 143105 (2010).
17. S. Prosvirnin, N. Papasimakis, V. Fedotov, S. Zouhdi, and N. Zheludev, *Trapped-mode resonances in planar metamaterials with high structural symmetry*, in *Metamaterials and Plasmonics: Fundamentals, Modelling, Applications*, edited by S. Zouhdi, A. Sihvola, and A. P. Vinogradov. (Springer, The Netherlands, 2009) pp. 201–208.
18. M. N. Kawakatsu, V. A. Dmitriev and S. L. Prosvirnin, *J. Electromagn. Waves Appl.* **24**, 261–270 (2010).
19. N. Papasimakis, Y. H. Fu, V. A. Fedotov, S. L. Prosvirnin, D. P. Tsai, and N. I. Zheludev, *Appl. Phys. Lett.* **94**, 211902 (2009).
20. V. R. Tuz, S. L. Prosvirnin, and L. A. Kochetova, *Phys. Rev. B* **82**, 233402 (2010).
21. M. Razeghi, *Eur. Phys. J. Appl. Phys.* **23**, 149–205 (2003).
22. D. A. B. Miller, S. D. Smith, and A. Johnston, *Appl. Phys. Lett.* **35**, 658–660 (1979).
23. D. Weaire, B. S. Wherrett, D. A. B. Miller, and S. D. Smith, *Opt. Lett.* **4**, 331–333 (1979).
24. A. E. Smith, R. G. McDuff, and N. R. Heckenberg, *J. Opt. Soc. Am. B* **12**, 393–400 (1995).
25. S. L. Prosvirnin, *J. Commun. Technol. Electronics* **44**, 635–639 (1999).
26. A. E. Miroshnichenko, S. Flach, and Y. S. Kivshar, *Rev. Mod. Phys.* **82**, 2257–2298 (2010).