

USAGE OF MECHANICALLY SWITCHING DEVICES FOR HV ELECTROSTATIC ELEMENTS OF BEAM OPTICS

Alexander Mikhailichenko, CHESS, Ithaca, NY 14853

Abstract. We are considering usage of gas-filled mechanical relays- Kilovacs and Gigavacs-for power supply of HV electrical Dipoles, Quadrupoles *etc.* where even a time dependent regime required. One can expect the physical switching time on few nanosecond level with such devices operating up to 70 kV with currents of ~50 A.

1. INTRODUCTION

Mostly elements of beam focusing systems used in storage rings and beam transport channels are the magnetic ones: Dipoles, Quadrupoles *etc.* Electrostatic elements are represented there as some specific elements such as kickers, electrostatic separators, septa, quadrupoles *etc.* For example, usage of electrostatic quadrupoles for vertical focusing of muons in dedicated ($g-2$) ring is a key concept of E-989 (E-821) experiment performed for measurement of anomalous magnetic moment of muon. One peculiarity with quadrupoles in this experiment is that the dipole component of electric field should be introduced for a short period of time of the order $16\mu s$ for scrapping particles with large amplitudes [1].

Some minor comments could be done about technical realization of electric scheme in E-821. For example the HV feedthroughs should be not attached to the flange by tubes (see Fig.8 of [1])-as the HV wires should be a shadow of insulator. So the necks of these wires at the level of flange plane should not be exposed to the elevated field strength allowing development of corona discharge.

In [2] described the scheme for Quadrupole PS for E-989 experiment. Pretty much it is the same scheme as it is described in [1]. One statement could be criticized there too. The maximal current in a circuit which runs for a sub microsecond level associated with charging the parasitic capacitance associated with feeding cables ($C_4=C_6=3nF$, Fig.1 [2]). The maximal level of current comes to be $I_{max}=U/R_6=32kV/100\Omega=320A$, which lasts for a time $\tau=R_6C_4=100\Omega\times 3nF=300ns$ only. But the authors come to conclusion that the PS should be able to generate this ~400A current for entire millisecond, suggesting thyatron switches for T1-T3. One obvious solution for reduction of this current (and type of switch) associated with reduction of parasitic capacitance and increase of serial resistance.

Below, upon example of Quadrupole for E-989 [3] we are considering one possibility to feed the HV electrostatic elements with *mechanical* HV switching relays- Kilovacs and gigavacs.

2. KILOVAC AND GIGAVAC FAMILY

One type of HV relay is so called Kilovacs (see Addendum). Basically this is a mechanical relay with contacts moved by an electromagnet. Kilovac family interesting for our purposes includes K70A, K70B and K70C. The last one has three contacts which allow the central one switching between two positions. These Kilovacs are filled with pressurized SF₆ gas. Other Kilovacs are H-19 and H-17 are vacuumed with Tungsten electrodes, see Addendum.

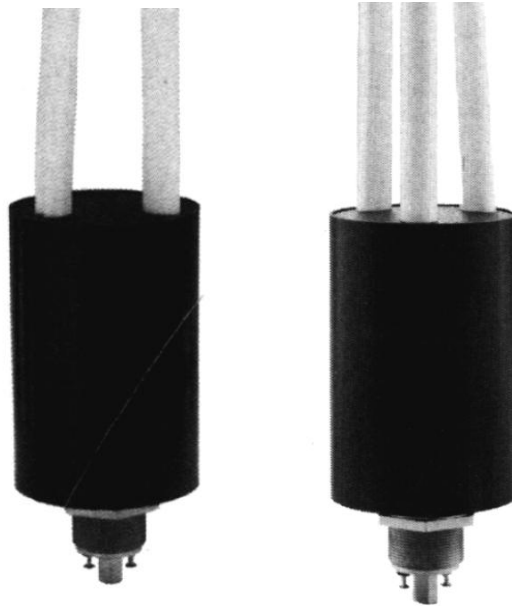

Figure 1. Model K70A,B at the left, K70C at the right. Diameter of the body is 2 inch. These Kilovacs commutate 70 kV at ~10 A.

Two parameters which characterize the switching time (see Addendum) are the operate (closing) and release times. The first parameter (closing time) is the time required for Kilovac to establish electric contact after a step of feeding voltage applied to the coil of electromagnet. Release time is a time between the moment, when the feeding voltage is turned off and the moment, when the electrical contact is broken. These times are indicated as they are of the order of 10-20ms. These times associated mostly with *mechanical* motion of contacts from the initial position to the final one and do not reflect physical closing/opening times.

3. EXPERIMENT WITH KILOVAC

As we already mentioned, in a specification (see Addendum) for Kilovacs, the closing time indicated as long as 6 to 20 milliseconds, depending on model. The release time is 15 ms maximum (for K70 family). This closing time indicates however the time counted from the beginning of voltage pulse, which is feeding the magnet of kilovac, to the moment of *physical* closing of contacts. But for our purposes namely that last duration of electrical closing is important, as the time required for mechanical acceleration of contacts to the moment of physical

closing of contacts is irrelevant for the closing time itself. One can think about this as of some delay; what is important- is the stability of this delay time from pulse to pulse.

Other specifics of *g-2* experiment E-989 taken as example, is that the the pulses are grouped in four trains by four pulses (16 total) [3]. Each pulse in a train separated by ~ 10 ms, the trains of four pulses each are separated by ~ 100 ms followed by deay time ~ 920 ms, so the period of sequence of all 16 pulses comes to 1.33 seconds, (i.e. 12 Hz for average power consumption balance). So there is a desire to turn off the quads, when there is no beam in a ring for reduction of sparking probability (which is proportional to the time when HV applied). So, definetely, there will be not a problem to turn of Kilovac for the interval of ~ 920 ms (time between trains containing 16 pulses) and for the time between train of four pulses (~ 100 ms).

To found what is the real closing time we used a simple arrangement with Kilovac H-12 in hand, Fig.2. This Kilovac has central contact and two others-one is “Normaly Cloced” to the central one and the other one is “Normally Open” to the central one. When the voltage applied to the kilovac coil, the central contact jumps to the one normally open.



Figure 2. Setup for test switching time of Kilovac H-12 (12 kV_{max} , 30 A_{min} , cost \sim \\$650). The probe which is attached to the normally open contact has 1:10 attenuation.

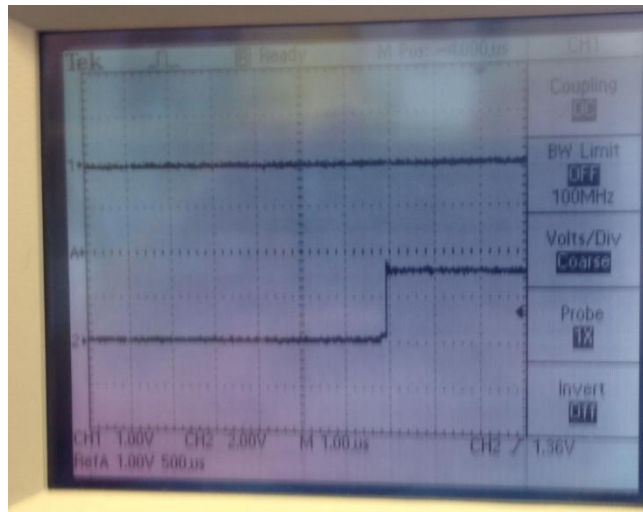

Figure 3. The rise time of voltage; horizontal time scale $1\mu\text{s}/\text{div}$, lower ray. Driving voltage applied to the coil of Kilovac $\sim 24\text{ V}$.

One can see that the real contact time is well below a microsecond. To investigate dependence of opening/closing time on the feeding voltage applied to the coil, a dedicated voltage source was used able to work with regulating output voltage. It was found that minimal voltage required for Kilovac H-12 to close contact is $\sim 12\text{V}$. In Fig. 4 there is shown the reaction of Kilovac on applied voltage $\sim 15\text{V}$.



Figure 4. Upper ray-the driving voltage applied to the coil of Kilovac (negative, attenuated 1:10)
 Lower ray-is the voltage at Kilovac's "Normally Open" contact (positive, attenuated 1:10).
 Commutating voltage $\sim 50\text{V}$; $25\text{ ms}/\text{div}$.

One can see that the closing time delay comes to $\sim 30\text{ ms}$, and the opening time delay comes to $\sim 7\text{ms}$. So there is a possibility for optimization of operation by changing the time profile of the voltage applied to the coil of electromagnet. It looks that the profile of voltage close to the triangle (trapezoidal, more exactly) might be the best one.

4. SCHEME WITH KILOVACS FOR QUADRUPOLES OF *g-2* EXPERIMENT

So as the HV Quadrupole (Dipole etc.) does not required current for its steady operation, just for the moments of charging/recharging, the thyratrons could be excluded. The charging current could be restricted to the value handled by Kilovac by choosing appropriated resistors in series. So for the limiting current, say 50A and voltage 30kV, the resistor value should be not less, than $R=30kV/50A=600\Omega$ only. To keep the resistor value located at the input of Quad higher than this minimal value, allows limiting the discharge current in a case of sparking between the electrodes and ground.

An example of quadrupole PS for *g-2* experiment is represented in Fig. 4. High frequency transformer, rectifying diodes, Kilovacs, resistors are located at the input of HV of the ring vacuum chamber in a sealed canister (see Fig.6). All elements of PS are immersed in Fluorinert for better insulation and cooling. Dielectric permittivity of Fluorinert $\epsilon\sim 1.9$ does not add much to the parasitic capacitance.

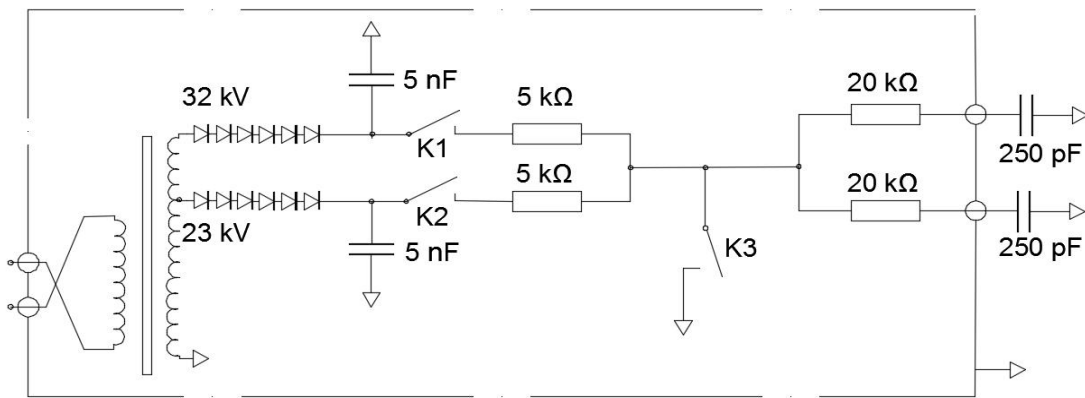

Figure 4. An example of electrical scheme of the Quadrupole PS for the positive polarity. For negative polarity the diodes with reversed polarity uses the same transformer taps. Kilovacs marked by K1-K3; for K1-K3 the K70A used, for K3 the model K70C could be used alsoused. Entire volume filled with Flourinert. The scheme is shown in a neutral position.

Simultaneous closing of K1 and K2 in a scheme in Fig.4 does not create a problem as the loop from lower HV will be electrically closed. So the total number of Kilovacs required with this scheme per quad is three for polarity which HV value should be changed¹⁾ comes to five totals. Transformer is feed by high frequency bi-polar pulses and operates at few tens kHz (50-70kHz). This allows transformer to be a compact unit. There are lots of high voltage diodes operating at this frequency. Semtech[®] SHVM15F may serve as example; this diode holds 15kV reversed voltage and direct DC current is limited by 0.35A while repetitive pulsed one could be as high as 8A. Feeding of Kilovacs are going from special board with transistors amplifiers delivering 1ms-long pulses of 12-24V.

¹ Other polarity does not require change of voltage during entire presence of the beam in a ring .

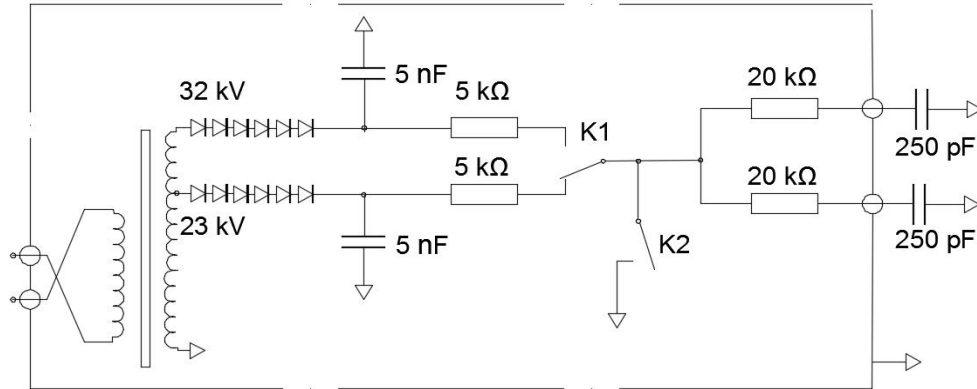

Figure 5. The scheme with two Kilovacs. This scheme is useful for switching between two voltages when usage of K2 is occasional. For K1 the K70C should be used.

The scheme in Fig. 5 might be useful if the switching between voltages could be of the order of 10-20ms. It might be useful for the (g-2) E-989 time pattern also, if the 23 kV voltages turned on in advance, and switching to the 32 kV happen $\sim 15 \mu\text{s}$ after injection. Voltages and timing should be arranged so, that grounding of electrodes with K2 happens while the contacts of K1 are traveling between two states (from 32kV to 23 kV).

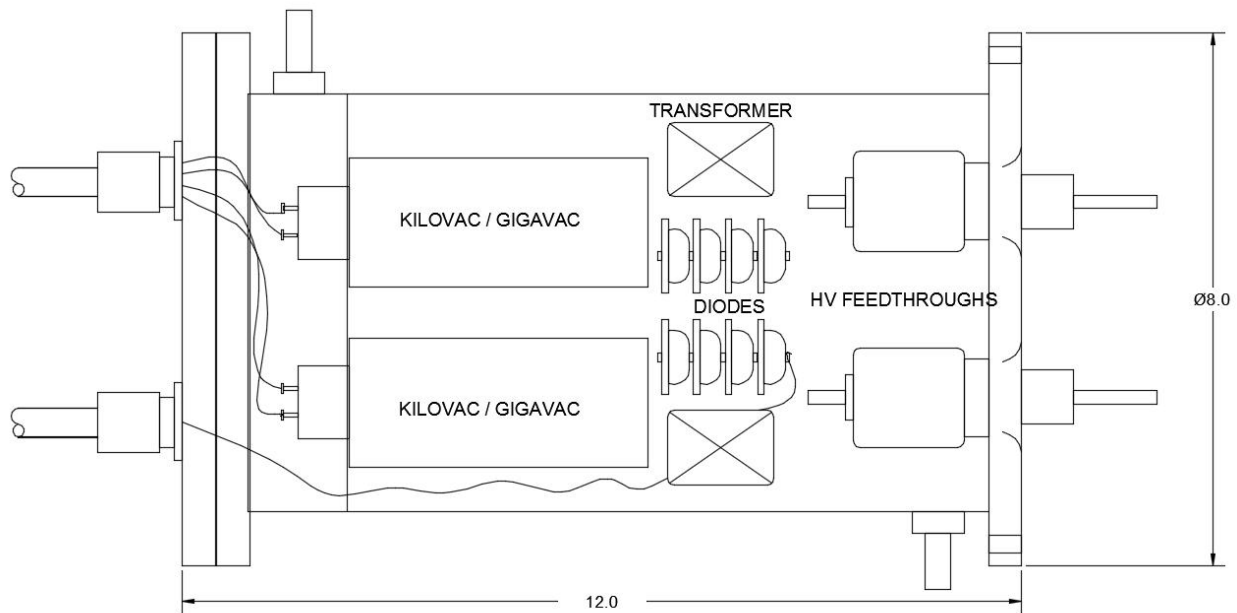

Figure 6. The PS schematics from Fig.4 and Fig.5. Dimensions are given in inches ($\text{Ø}8''$, height = 12''); this PS supply mounted on the input flange of HV Quadrupole input. Entire volume filled with Fluorinert.

The transistor board for switching Kilovacs is not shown here; it is located in close vicinity.

DISCUSSION

Usage of Kilovacs and Gigavacs in HV accelerator elements such as electrostatic Dipoles, Quadrupoles, etc. and for charging capacitors, open an interesting possibility for simplification

of these devices and lowering their cost. Implementation of Kilovac in each case should be done after test of such device at full voltage and frequency of switching rate (100Hz at max, 12 Hz average for g-2).

Short time of physical contact closing demonstrated is not surprising, as the sparking devices are widely used in a commutation elements; one can think, that in a case of mechanical relays, the triggering happens when the contacts are close enough, while in switches the triggering arranged with the help of initiating discharge or arrangement of instant overvoltage of the gap (for three-electrode sparking switches). As far as the release time, it should be investigated for each specific model. The possibilities here are in lowering and profiling feeding voltage and current. More radical could be usage of *magnetized* core of electromagnet, so it becomes sensitive to polarity of the feeding current. The relays with latching contacts operated with two separate coils for closing and opening open wide possibilities for optimization of open/closing times. One example of such devices are G64L and G71L from Gigavac[®], see Addendum.

REFERENCES

- [1] Y.Semertzidis *et.al.*, “*The Brookhaven Muon (g-2) Storage Ring High Voltage Quadrupoles*”, NIM A 503 (2003) 458-484.
- [2] V.Tishenko *et.al.*, “*Requirements Document for the High Voltage Pulser for Electrostatic Focusing Quadrupoles*”, E-989-doc-2512, Feb 4, 2015.
- [3] J.Grange *et.al.*,”*Muon (g-2) Technical Design Report*”, FERMILAB-FN-0992-E, Jan 27, 2015, 666 pp., e-Print: [arXiv:1501.06858](https://arxiv.org/abs/1501.06858).

ADDENDUM.

Screenshots from official sites of Companies



20 / 25 kV

Kilovac H-19 *Make & Break Load Switching*



Features:

- 20 kV operating voltage
- Vacuum dielectric and tungsten contacts for power switching low current loads
- Double pole, double throw contacts
- Available with corona shield connectors
- Meets requirements of MIL-R-83725

Kilovac H-17 *Make & Break Load Switching*



Features:

- Will isolate 12 kV at 32 MHz
- Tungsten contacts suitable for power switching low current loads
- Available with corona shield connectors
- Meets requirements of MIL-R-83725
- QPL version available, M837252

PRODUCT SPECIFICATIONS			
Part Number	Units	H-19	H-17
Contact Arrangement		DPDT	SPDT
Contact Form		2C	C
Test Voltage (dc or 60Hz)	kV Peak	25	30
Rated Operating Voltage	kV Peak		
dc or 60 Hz		20	25
2.5 MHz		15	20
16 MHz		10	15
32 MHz		7	12
Continuous Carry Current, Maximum	Amps		
dc or 60 Hz		30	30
2.5 MHz		18	16
16 MHz		9	10
32 MHz		6	8
Coil H-Pot (V RMS, 60 Hz)		500	500
Contact Capacitance	pF		
Between Open Contacts		1	1
Open Contacts to Ground		2.5	2.5
Contact Resistance, Maximum	ohms	0.015	0.015
Operate Time, Maximum	ms	30	25
Release Time, Maximum	ms	20	25
Shock, 11 ms 1/2 Sine	Peak G's	30	20
Vibration, 10 G's Peak	Hz	55-500	55-500
Operating Ambient Temperature Range	°C	-55 to +125	-55 to +125
Mechanical Life (Operations x 10 ⁶)	Cycles	1	1
Weight, Nominal	oz.	6.5	7

COIL DATA			
Nominal, Volts dc	12	26.5	115
Pickup, Volts dc, Maximum	8	16	80
Drop-Out, Volts dc	.5 - 5	1 - 10	5 - 50
Coil Resistance (Ohms ± 10%)	H-19	48	225
	H-17	24	120
		2900	

Ratings listed are for 25°C, sea level conditions

PART NUMBER SELECTION

Sample Part No. H- 17 /12Vdc
 Model
 H-19
 H-17
 Coil Voltage
 Blank = 26.5 Vdc
 /12Vdc = 12 Vdc
 /115Vdc = 115 Vdc

Kilovac K70A, K70B Make Only



Features:

- New, small, compact 70 kV relay package
- SF-6 gas-filled for capacitive discharge and high voltage isolation applications
- Ideal for charging and discharging of high voltage capacitors
- Safe for use in adverse environments

Kilovac K70C Make Only



Features:

- SPDT version of K70A
- SF-6 gas-filled for capacitive discharge and high voltage isolation applications
- Ideal for charging and discharging of high voltage capacitors

COST ~ \$1400.

PRODUCT SPECIFICATIONS				
Part Number	Units	K70A	K70B	K70C
Contact Arrangement		SPST-NO	SPST-NC	SPDT
Contact Form		A	B	C
Test Voltage (dc)		75	75	75
Rated Operating Voltage	kV Peak			
dc		70	70	70
60 Hz RMS, kW Peak		30	30	30
2.5 MHz		-	-	-
16 MHz		-	-	-
32 MHz		-	-	-
Continuous Carry Current, Maximum	Amps			
dc or 60 Hz		10	10	10
2.5 MHz		-	-	-
16 MHz		-	-	-
32 MHz		-	-	-
Coil Hi-Pot (V RMS, 60 Hz)		500	500	500
Contact Capacitance	pF			
Between Open Contacts		-	-	-
Open Contacts to Ground		-	-	-
Contact Resistance, Maximum	ohms	2.0*	2.0*	2.0*
Operate Time, Maximum	ms	20	20	20
Release Time, Maximum	ms	15	15	15
Shock, 11 ms 1/2 Sine	Peak G's	20	20	20
Vibration, 10 G's Peak	Hz	55-500	55-500	55-500
Operating Ambient Temperature Range	°C	0 to +85	0 to +85	0 to +85
Mechanical Life (Operations x 10 ⁶)	Cycles	0.5	0.5	0.5
Weight, Nominal	oz.	18	18	18

COIL DATA	
Nominal, Volts dc	26.5
Pickup, Volts dc, Maximum	22
Drop-Out, Volts dc	1 - 10
Coil Resistance (Ohms ±10%)	75

Ratings listed are for 25°C, sea level conditions

PART NUMBER SELECTION

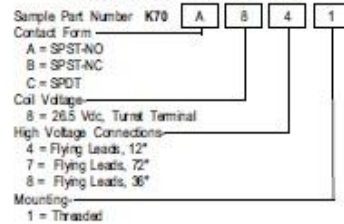

* Contact resistance for gas-filled relays measured at 28 Vdc, 1 Amp

G71L - LATCHING

70 kV

Make Only Load Switching
RoHS Compliant



FEATURES	
<ul style="list-style-type: none"> Latching coils for low power consumption and to ensure relay will remain in last position, even when no voltage is applied to the coil 	
G71LA	
<ul style="list-style-type: none"> Sealed 70 kV isolation in about 6.3 cubic inch (100 cubic cm) package - your will be system the smallest in the industry! SF-6 gas filled for capacitive discharge with no x-ray emissions Pre-tinned, optional length, high voltage leads making installation easy fast and easy Great for charging & discharging capacitors with no bounce under load GIGAVAC exclusive replaceable coils 	
G71LC	
<ul style="list-style-type: none"> Same great features as the G71A and G71B Double Throw (SPDT) for polarity reversal and multiple power source switching 	

PRODUCT SPECIFICATIONS				
Contact & Relay Ratings	Units	G71LA	G71LC	
Contact Form		A	C	
Contact Arrangement		SPST	SPDT	
Voltage, Test Max., Contacts & to Base (15 µA Leakage Max, dc or 60Hz)	kV Peak	75	75	
Voltage, Operating Max., Contacts & to Base (15 µA Leakage Max.)				
dc	kV Peak	70	70	
60 Hz RMS	kV Peak	30	30	
2.5 MHz	kV Peak	-	-	
16 MHz	kV Peak	-	-	
32 MHz	kV Peak	-	-	
Current, Continuous Carry Max				
dc or 60 Hz	Amps	10	10	
2.5 MHz	Amps	-	-	
16 MHz	Amps	-	-	
32 MHz	Amps	-	-	
Coil Hi-Pot (V RMS, 60 Hz)	V	500	500	
Capacitance				
Across Open Contacts	pF	-	-	
Contacts to Ground	pF	-	-	
Resistance, Contact Max @ 1A, 28 Vdc	ohms	2.0*	2.0*	
Operate Time	ms	20	20	
Reset Time	ms	15	15	
Life, Mechanical	cycles	.5 million	.5 million	
Weight, Nominal	g (oz)	336 (12)	336 (12)	
Vibration, Operating, Sine (55-500 Hz Peak)	G's	10	10	
Shock, Operating, 1/2 Sine 11ms (Peak)	G's	20	20	
Temperature Ambient Operating	°C	-50 to +85	-50 to +85	

COIL RATINGS	
Nominal, Volts dc	26.5
Pick-up, Volts dc, Max.	22
Reset, Volts dc	1 - 10
Coil Resistance (Ohms ±10%)	-

Ratings listed are for 25°C, sea level conditions.
Coils are polarity sensitive.
Observe polarity marked on coil terminals.

For more information, refer to

Relay User Instructions

G71 L A 8 4 1

Latching Designator

Contact Form
A = SPST
C = SPDT

Coil Voltage **
8 = 26.5 Vdc, Turret Terminal

High Voltage Connections
4 = Flying Leads, 12"
7 = Flying Leads, 72"
8 = Flying Leads, 36"

Mounting
1 = Threaded

*Contact resistance for gas-filled measured at 28 Vdc, 1 Amp

**Order the relay with the part number as shown. The latching "L" designator and the coil voltage will not appear in the P/N on the relay but will be indicated on the label that is on the base of the relay. Observe coil polarity.

09/06/11

GIGAVAC®

GIGAVAC® - P.O. Box 4428 - Santa Barbara, CA 93140-4428 - ph +(805) 684-8401 - +(805) 755-2000
fx +(805) 684-8402 - info@gigavac.com - www.gigavac.com - ©Copyright 2003-2011 GIGAVAC, LLC.